

MADE IN ITALY



INDUSTRIAL range



K-MAX TS

Two-stage rotary screw compressors with variable speed and flow rate



75-315 kW



NEW

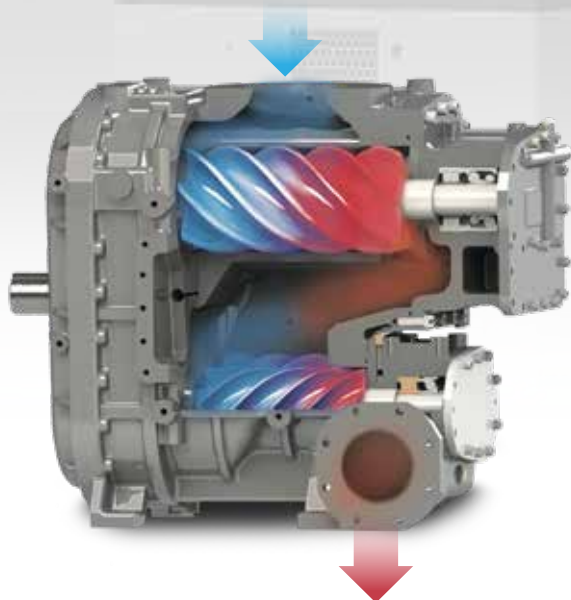

With the introduction of the TS models in the K-MAX series, Fini is once more redefining the standard in terms of efficiency, reliability, ease of maintenance and available energy savings.

Designed to last.



The K-MAX range now includes the new TS series: air-cooled, two-stage rotary screw compressors with power ratings from 75 kW to 315 kW, with variable speed and flow rate, supplied ready for use and complete with all the components required for safe and reliable operation, driven by a premium high-efficiency electric motor. The two-stage range represents the ultimate advancement in oil-injected screw compressor technology today, ensuring a very high level of reliability and unrivalled performance in a fully integrated and technically advanced solution.



K-MAX^{TS}

A complete range from 75 kW to 315 kW, in air-cooled versions, with variable speed and flow rates: 3 sizes, 24 available configurations.

The K-MAX TS two-stage range, entirely manufactured in Italy at our plant in Bologna, has been designed by our engineering team with the support of our experienced after-sales service technicians to achieve a compressor that meets the requirements of the most demanding users, with particular regard to energy saving, silenced operation and with ease of maintenance in mind.

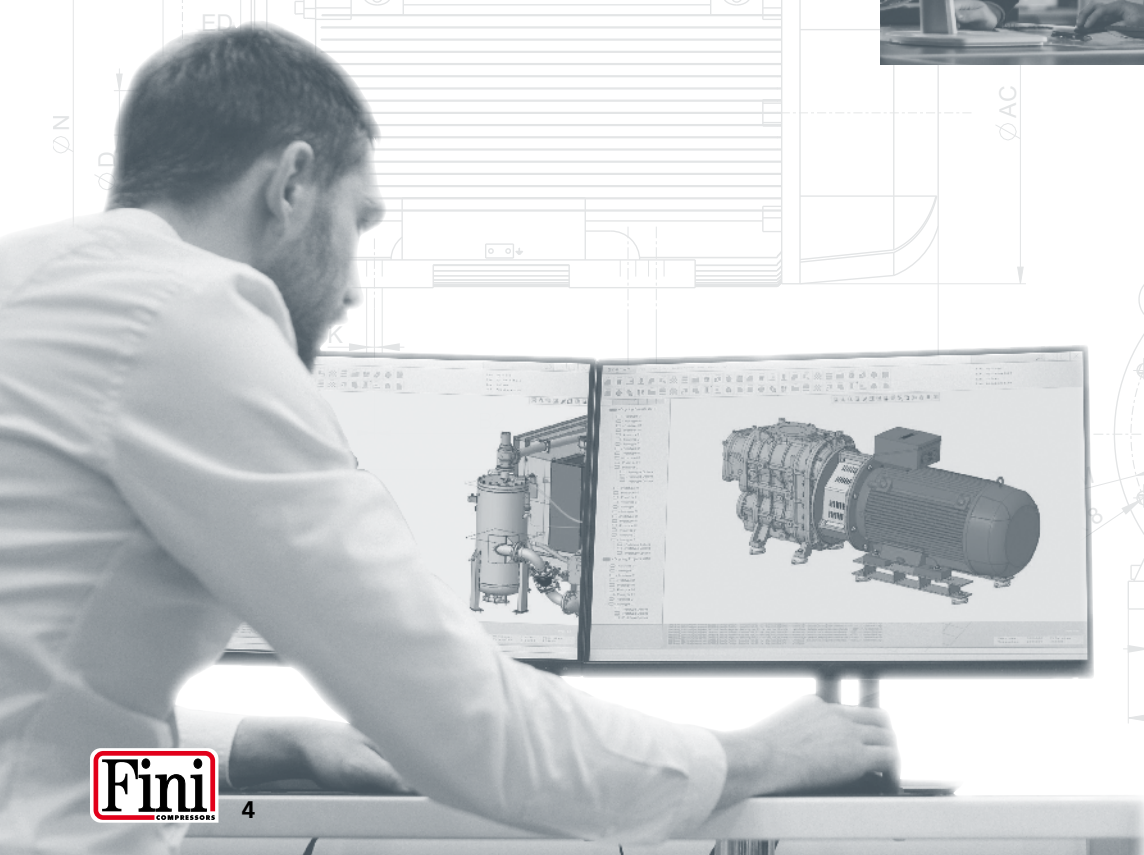
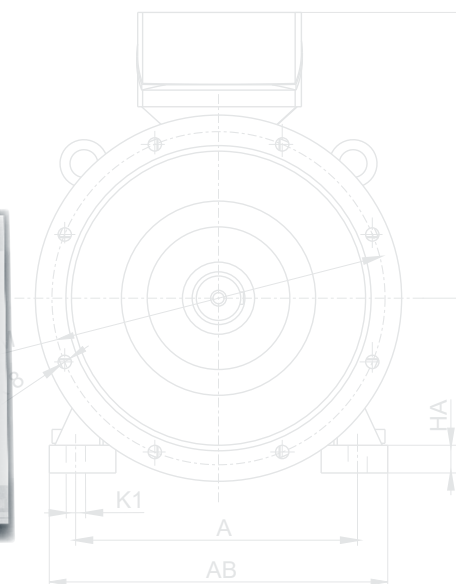
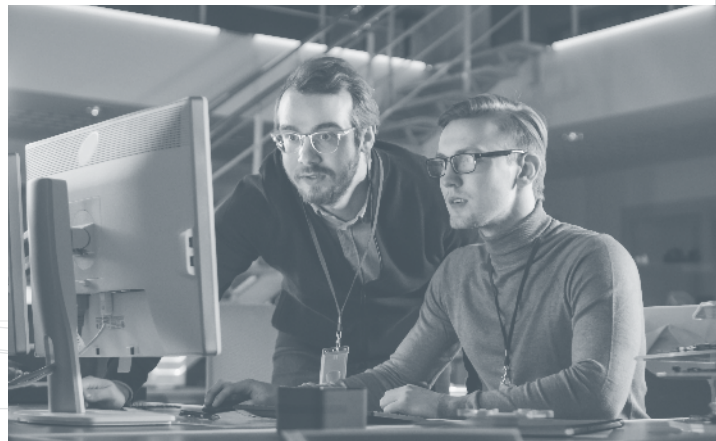

Born out of experience and know how.



K-MAX TS

In Europe, compressed air production accounts for approximately **14% of total energy consumption in the industrial sector.**

In order to achieve a sustainable future and to be more competitive in the market, there is a major challenge to face: increasing the efficiency of compressed air systems used in industry!

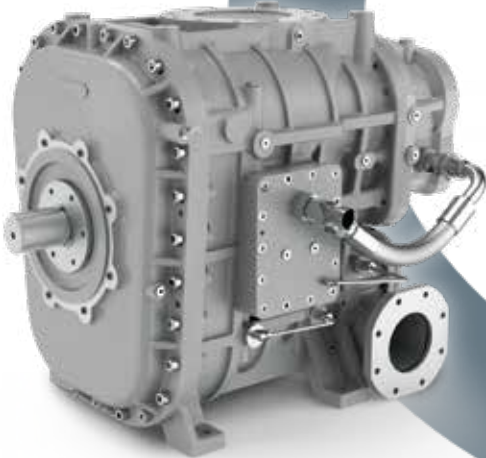

The two-stage K-MAX TS range, with its new and exclusive two-stage air-end, meets this challenge.

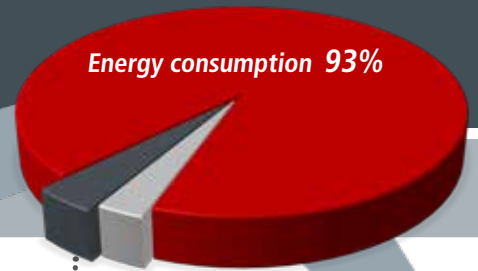

Investment 4% Maintenance 3%

The graph indicates the breakdown of the total costs during the life cycle of a Single-stage compressor appropriate to five years of use, considering 6000 working hours per year.

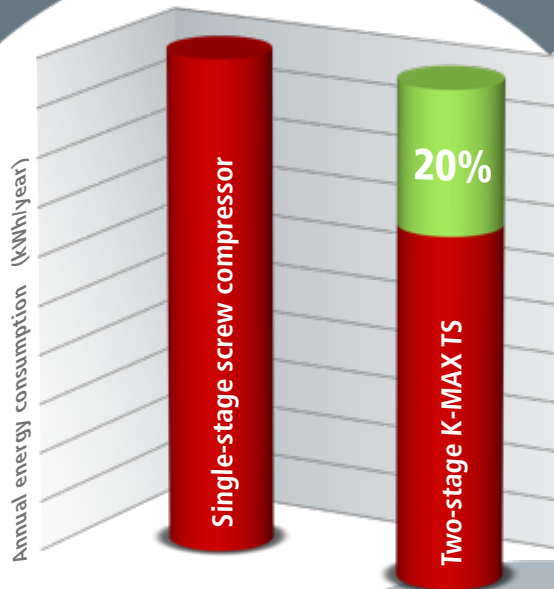

● Energy consumption
● Energy saving

The histogram shows the estimated annual energy savings of our K-MAX TS two-stage compressor compared to a Single-stage compressor with the same power.

Return on Investment

Comparing a Single-stage compressor with our two-stage compressor, with the same volume flow, considering 6,000 working hours per year and with a 70% duty cycle, it is possible to estimate that the acquisition investment in our K-MAX TS can be recouped in less than 24 months from installation.

Efficiency is also synonymous with sustainability.



Why choose a K-MAX TS?

Because they consume less

Our two-stage K-MAX TS compressor allows energy savings of up to 20% compared to a similarly powered single-stage compressors.

Because they are designed to last

The two-stage air-end technology ensures less wear and greater longevity for the compressor because the final pressure is divided between the two compression stages.

Because their efficiency is always under control

All K-MAX TS functions are fully controlled by the integrated electronic "Login" controller, which constantly monitors the compressor.

Because they are designed for industrial applications

Compressed air is an essential energy source in the production processes of medium and large-scale industries, operating in a wide variety of sectors.

Thanks to our innovative two-stage technology, the K-MAX TS models ensure a constant and reliable supply of compressed air.

Eco-friendly technology

The search for energy efficiency in the production processes of industry is one of the main challenges we face in order to maintain our competitive advantage in the market.

We also seek to optimise the sustainability of our processes at the same time. Living sustainably means preserving our natural resources as much as possible. Choosing a K-MAX TS product, reducing energy consumption and CO₂ emissions, therefore, represents the most ecological choice.



Integrated heat recovery system

K-MAX TS is designed to include an integrated water-oil plate exchanger (option) that allows the recovery of energy that may be converted into heat, suitable as an energy source to provide heated water for room heating, washrooms and for many industrial applications.

K-MAX TS

Oil separator vessel

The highly efficient design guarantees excellent compressed air quality with a very low residual oil content (less than 2 parts per million by weight). The separator element is easier to replace thanks to the sliding lid of the vessel (1-2), which facilitates convenient element replacement (3), reducing downtime and maintenance time.



Oil filter housing complete with thermostatic valve

The filter cartridges are of the screw-on type, making them simple to replace in a clean, safe way reducing the risk of oil spillage.

The thermostatic valve is located in a position that is immediately accessible and convenient to check/maintain. The thermostatic valve controls the oil flow avoiding sudden temperature changes and reduces the formation of condensate inside the lubrication circuit.

It is not necessary to remove the oil from the radiator in order to replace it or for service.



Damping joint

This allows for the suppression of possible stresses and for the use of rigid pipes thus avoiding the risk of failure.

Maintenance operations are simplified because the pipe can be disconnected without misalignment of the two flanges.

Integrated design

K-MAX TS compressors have been designed to ensure perfect accessibility to the internal components. This is achieved by paying care full attention to both the layout and design. All sides of the machine can be accessed easily thanks to flush-mounted hinged doors for ease of maintenance.

Silencer

- The exclusive and unique
- soundproof chamber has been
- developed to ensure maximum
- silencing and to maintain
- high suction efficiency.

Suction filter

- The pocket type filtering
- element is designed to ensure
- minimum pressure drop and
- maximum filtration efficiency.
- Maintenance is facilitated
- through the easily accessible
- and removable external panel,
- with no need to enter
- the main machine.

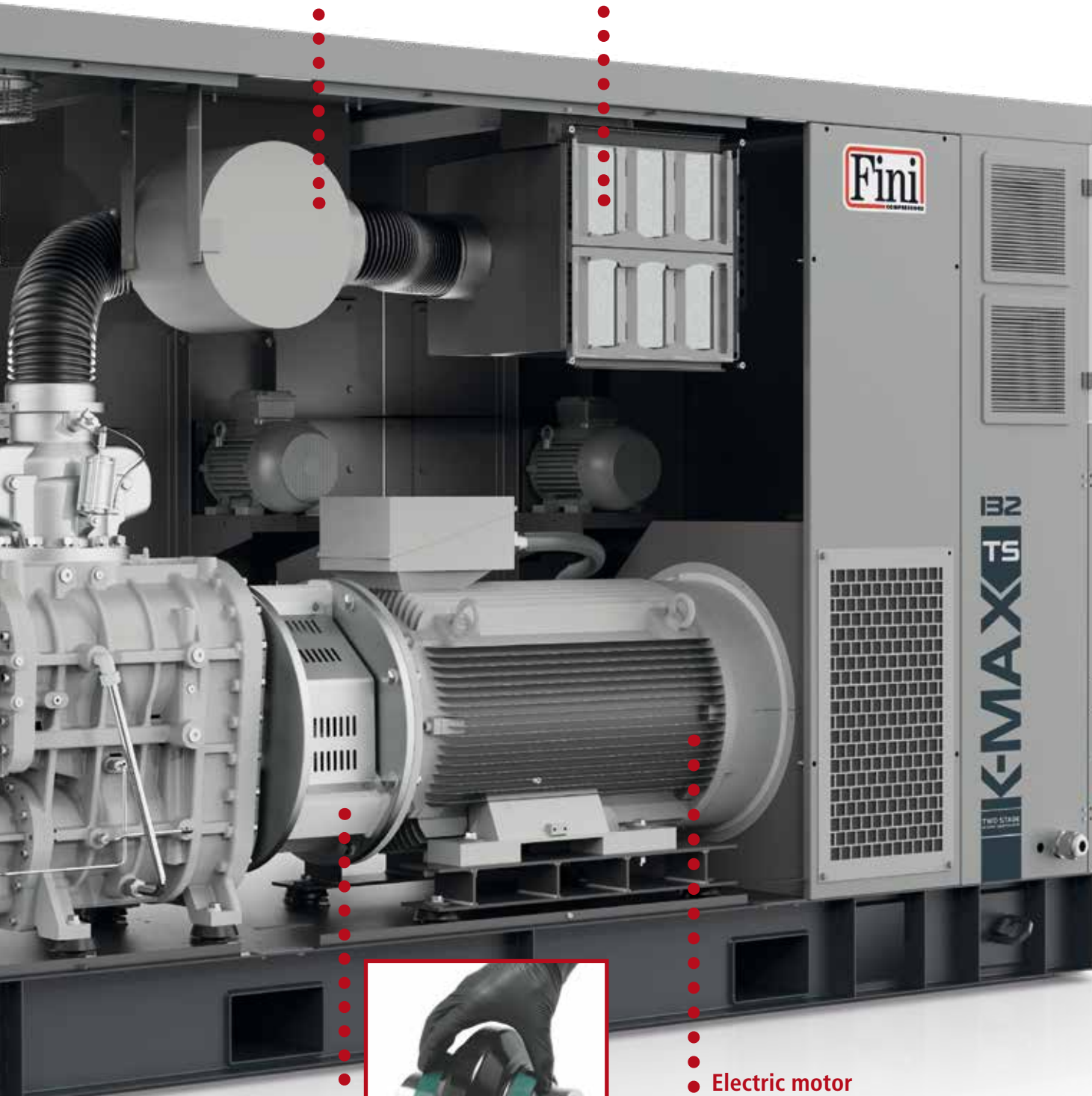

Flexible coupling

With elastic insert that is both easily accessible and simply removed during longer term maintenance.



Electric motor

- Electric motor with energy
- efficiency class IE4
- 'Super Premium Efficiency'.

K-MAX TS

Soundproof cabinet

Manufactured from heavy gauge steel and with applied multi-layer protective coating. The cabinet is completely lined internally with high-density sound-absorbing material, reducing the overall sound level to extremely low values. The cabinet consists of panels that can be easily opened or removed for quick inspection and maintenance. The cabinet is solidly fixed to a steel support frame that is also designed to allow the safe and convenient lifting and positioning of the compressor.

Cooling system

The individually sized cooling system allows K-MAX TS to operate at full load even under severe conditions in ambient temperatures of up to 45 °C. The cooling fans have a variable flow rate and are regulated by the central electronic controller. This ensures that the operating temperature of the machine and of the lubricant is kept constant, preserving efficiency and allowing a longer life to the lubricant.

Heat exchanger and ventilation unit

The innovative design simplifies maintenance of the heat exchanger and fan unit, as it can be removed either vertically or horizontally, using a lifting device or by removing it outwards on the wheels at the base. These wheels slide on special tracks (optional) specially designed for this purpose and can be supplied on request.

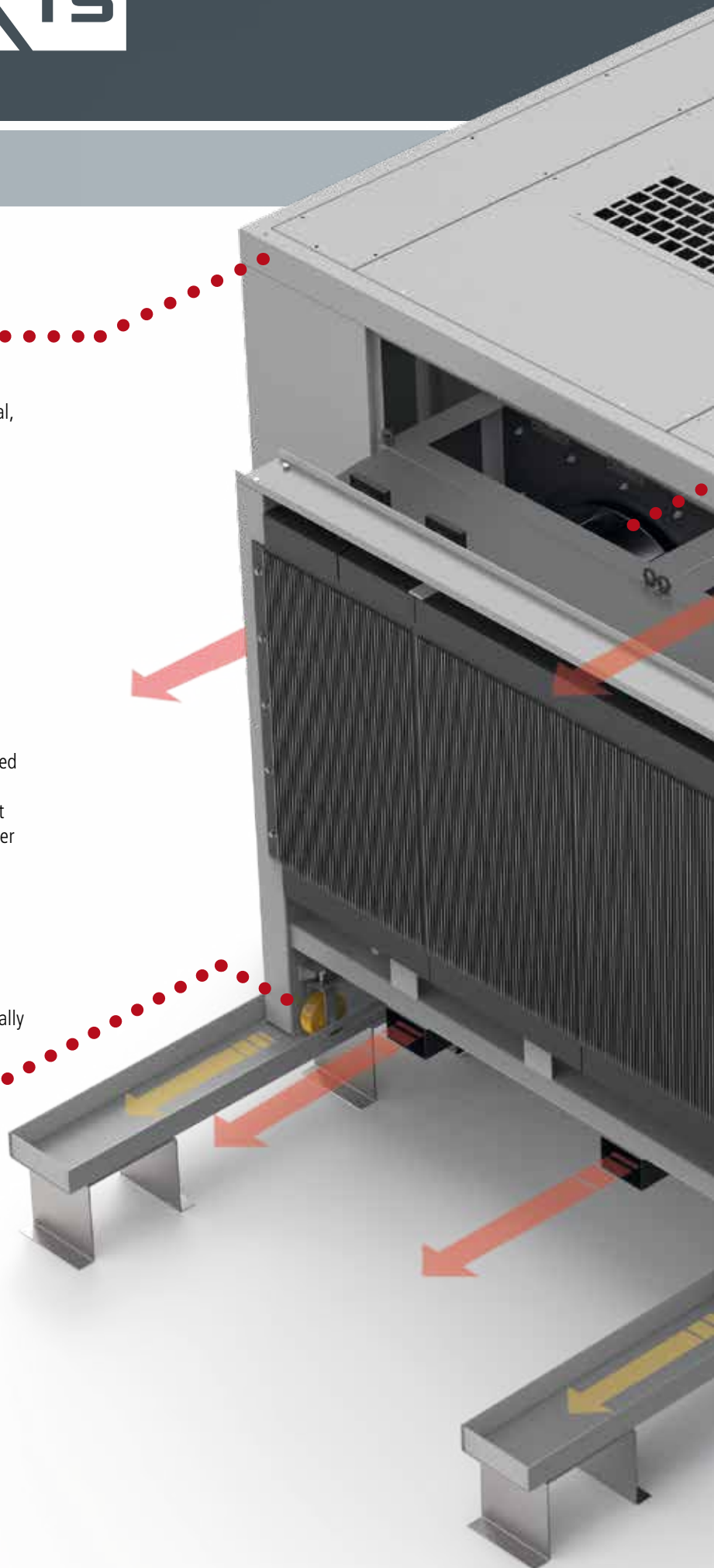



- **Efficient ventilation**

- K-MAX TS is equipped with a radial ventilation system, driven by an inverter and managed by the electronic controller. Quieter operation is also provided thanks to the use of soundproofing.

- **Compressor compartment ventilation**

- Fans installed for the extraction of heated air from the compressor compartment.

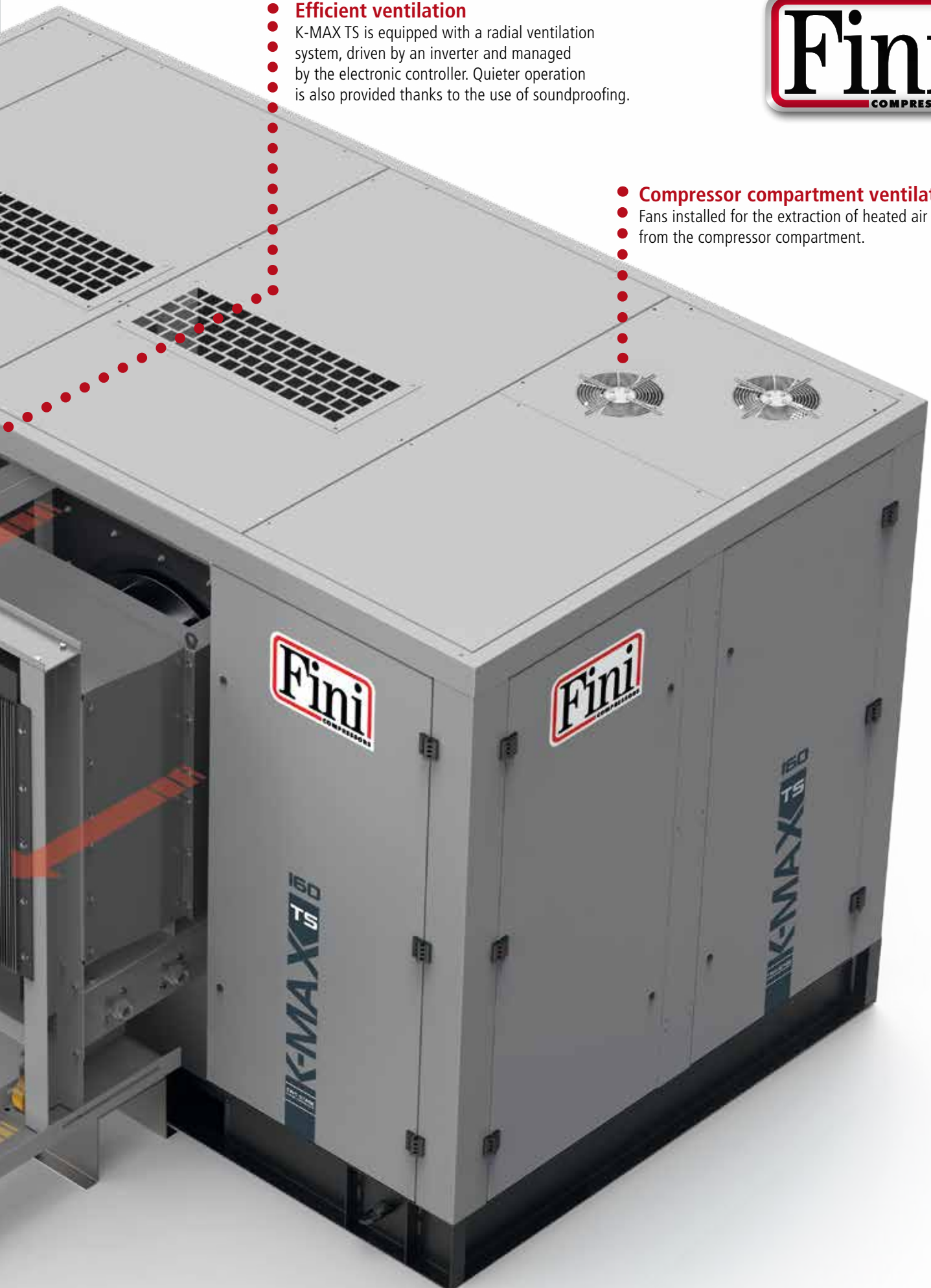



The best technology, applied to compressed air.

The new 'Login' controller introduces new software capabilities to strengthen diagnostic functions, thereby guaranteeing excellent performance in all conditions. Login provides additional facilities including remote control and multi-compressor management.

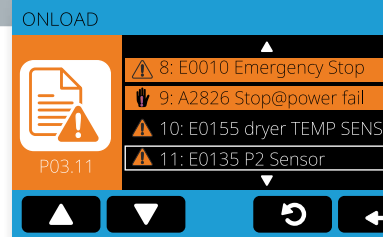

Intelligent control

All of K-MAX TS' functions are entirely managed by the centralised Login electronic controller, which constantly monitors the compressors operation ensuring efficient and reliable operation of the machine in all conditions with customised functions to suit any application

Always connected

During an irregular event within the machine, Login reports the presence of such and incident by creating an alert for the user, allowing for prompt operator intervention. The integrated connectivity with remote monitoring (optional), makes it possible to obtain complete information on the compressor status remotely.

Compressor rotation management

Thanks to the "ISC" system it is possible to simultaneously connect up to 8 different compressors (fixed and/or variable speed combinations), with "master-slave" logic. The system can also be used with other compressors not equipped with Login by using the optional modules suitable for specific compressors.



Exclusive design

Italian design, functionality, simple to use and with the latest generation technology all come together with the innovative Login controller. The touch-screen display and the icon-based menu make it extremely intuitive and easy to use.



Memory card slot

Login features a memory card slot which can be used to store compressor data and configurations and to transfer them to another control unit.



Multilanguage management

It is possible to select the local language from any of the 20 pre-installed languages.



Remote control

This allows a complete remote control of the compressor.



Multicolour display

All of the operational parameters are displayed on the large 4.3" colour screen which also displays graphs in real time (pressure, power, energy/time).



Designed for Industry 4.0

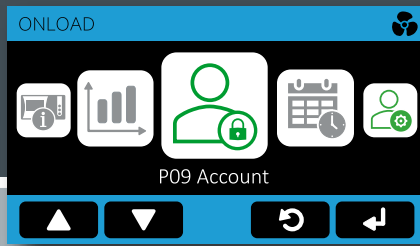
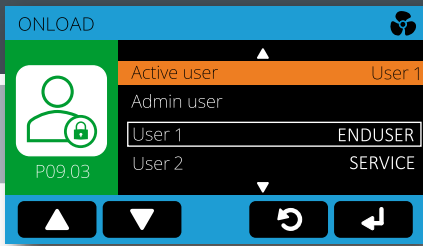

SMS 2.0

SMS 2.0 (Service Management System) is the innovative device (optional) to remotely access and perform preventive maintenance checks on any of the compressors fitted with a LOGIN controller.

Preventive and targeted maintenance

A LAN connection with Ethernet cable, SMS 2.0 allows e-mails to be sent automatically should an irregular event occur (up to 5 settable e-mail addresses). At the same time, it is possible to monitor the correct operation of the compressor and to check the scheduling for future maintenance interventions and checks.

SMS 2.0 is installed directly on the LOGIN controller, at the rear.

code #005560002



Compressor remote control

- online compressor status control (view of temperature and pressure parameters);
- on/off control;
- view of events and alarms;
- view of remaining hours for maintenance;
- graphic view of analogue signals connected to the controller, in real time;
- no additional software is needed.



75-90 kW

	Code	Power	Air outflow rate (min. / max.)		Max pressure**		Sound level	Air outlet	Net weight	Net dimensions
		kW	m ³ /min.	c.f.m.	bar	p.s.i.	dB(A)	DN	kg	L x P x H (mm)
75 kW										
K-MAX TS 75-07 VS	V60ZB97FNM045	75	5,48 / 16,60	194 / 586	7	101	73	DN50	3260	3000 x 2000 x 2200
K-MAX TS 75-08 VS		75	5,19 / 15,70	183 / 554	8	116	73	DN50	3260	3000 x 2000 x 2200
K-MAX TS 75-10 VS		75	4,65 / 14,10	164 / 498	10	145	73	DN50	3260	3000 x 2000 x 2200
90 kW										
K-MAX TS 90-07 VS	V60ZE97FNM045	90	6,34 / 19,20	224 / 678	7	101	73	DN50	3500	3000 x 2000 x 2200
K-MAX TS 90-08 VS		90	6,30 / 19,10	222 / 675	8	116	73	DN50	3500	3000 x 2000 x 2200
K-MAX TS 90-10 VS		90	5,61 / 17,00	198 / 600	10	145	73	DN50	3500	3000 x 2000 x 2200

110-160 kW

	Code	Power	Air outflow rate (min. / max.)		Max pressure**		Sound level	Air outlet	Net weight	Net dimensions
		kW	m ³ /min.	c.f.m.	bar	p.s.i.	dB(A)	DN	kg	L x P x H (mm)
110 kW										
K-MAX TS 110-07 VS	V60ZH97FNM045	110	8,22 / 24,90	290 / 879	7	101	76	DN80	5300	3600 x 2000 x 2250
K-MAX TS 110-08 VS		110	7,43 / 22,52	262 / 795	8	116	76	DN80	5300	3600 x 2000 x 2250
K-MAX TS 110-10 VS		110	6,99 / 21,19	247 / 748	10	145	76	DN80	5300	3600 x 2000 x 2250
132 kW										
K-MAX TS 132-07 VS	V60ZL97FNM045	132	9,24 / 28,00	326 / 989	7	101	76	DN80	5500	3600 x 2000 x 2250
K-MAX TS 132-08 VS		132	8,91 / 27,00	315 / 953	8	116	76	DN80	5500	3600 x 2000 x 2250
K-MAX TS 132-10 VS	V60ZM97FNM045	132	8,56 / 25,94	302 / 916	10	145	76	DN80	5730	3600 x 2000 x 2250
160 kW										
K-MAX TS 160-07 VS	V60ZP97FNM045	160	11,43 / 34,65	404 / 1224	7	101	76	DN80	5730	3600 x 2000 x 2250
K-MAX TS 160-08 VS		160	10,89 / 33,00	385 / 1165	8	116	76	DN80	5730	3600 x 2000 x 2250
K-MAX TS 160-10 VS	V60ZQ97FNM045	160	9,90 / 30,00	350 / 1059	10	145	76	DN80	5890	3600 x 2000 x 2250

200-315 kW

	Code	Power	Air outflow rate (min. / max.)		Max pressure**		Sound level	Air outlet	Net weight	Net dimensions
		kW	m ³ /min.	c.f.m.	bar	p.s.i.	dB(A)	DN	kg	L x P x H (mm)
200 kW										
K-MAX TS 200-07 VS	V60ZS97FNM045	200	14,35 / 43,50	507 / 1536	7	101	79	DN100	7310	4350 x 2250 x 2450
K-MAX TS 200-08 VS		200	13,43 / 40,70	474 / 1437	8	116	79	DN100	7310	4350 x 2250 x 2450
K-MAX TS 200-10 VS	V60ZT97FNM045	200	12,21 / 37,00	431 / 1307	10	145	79	DN100	7400	4350 x 2250 x 2450
250 kW										
K-MAX TS 250-07 VS	V60ZV97FNM045	250	17,65 / 53,50	623 / 1889	7	101	79	DN100	8440	4350 x 2250 x 2450
K-MAX TS 250-08 VS		250	16,85 / 51,05	595 / 1803	8	116	79	DN100	8440	4350 x 2250 x 2450
K-MAX TS 250-10 VS		250	14,88 / 45,10	525 / 1593	10	145	79	DN100	8440	4350 x 2250 x 2450
315 kW										
K-MAX TS 315-07 VS	V60ZY97FNM045	315	20,79 / 63,00	734 / 2225	7	101	79	DN100	8500	4350 x 2250 x 2450
K-MAX TS 315-08 VS		315	20,29 / 61,50	717 / 2172	8	116	79	DN100	8500	4350 x 2250 x 2450
K-MAX TS 315-10 VS		315	18,48 / 56,00	653 / 1978	10	145	79	DN100	8500	4350 x 2250 x 2450

** Max. pressure up to 13 bar on request.

The data and results were measured in accordance with standard ISO 1217.
The sound level was measured in accordance with ISO 2151, with a tolerance of ± 3 dB(A).

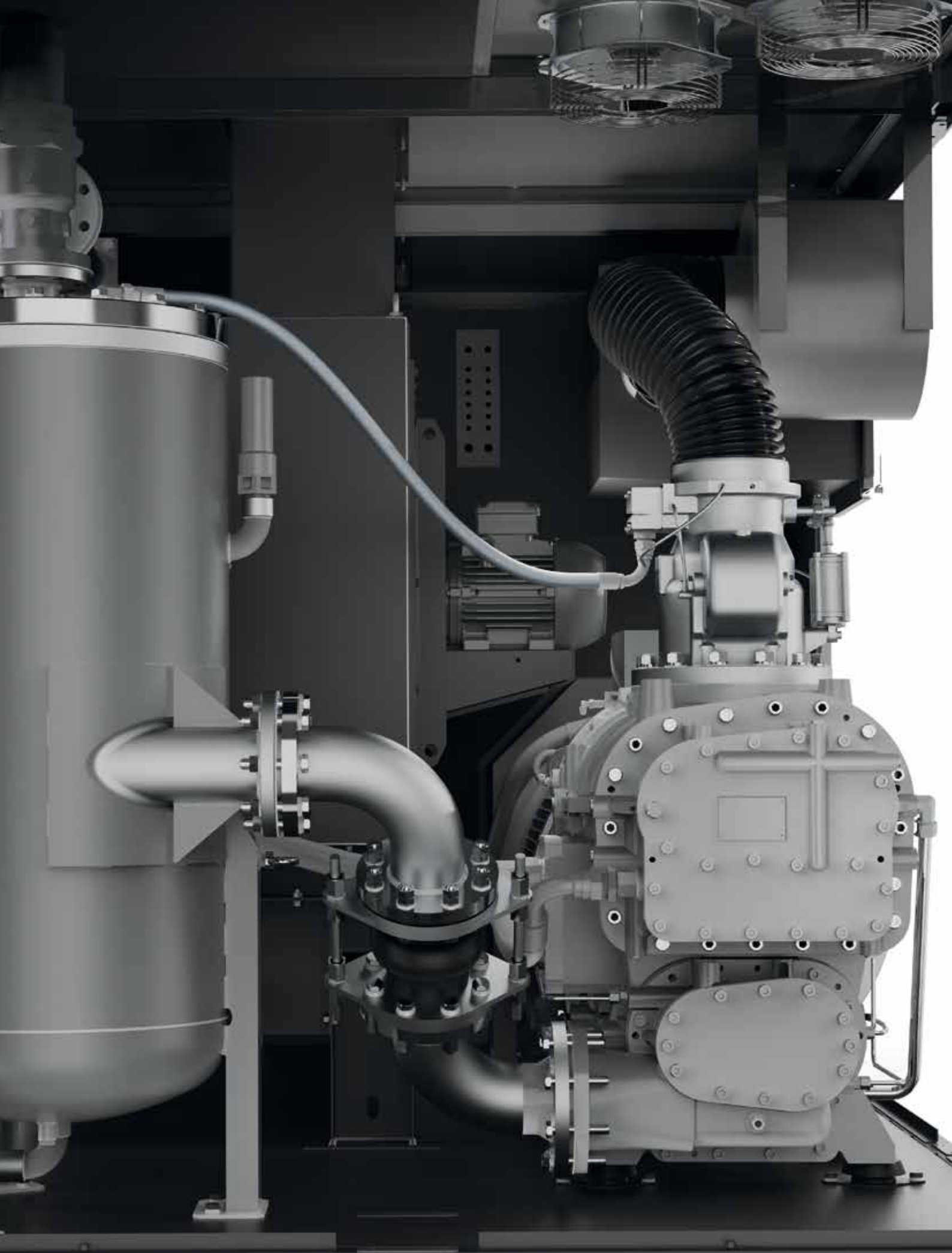

A wide range of solutions for industrial applications



TERA

Oil-injected rotary screw compressors with direct transmission without gears, at fixed or variable speed and power range from 110 to 250 kW.

K-MAX

Oil-injected rotary screw compressors with direct transmission, at fixed or variable speed, also with permanent magnet motors, and power range from 5.5 to 90 kW.

MiniCUBE

Oil-injected rotary screw compressors with direct transmission and power of 2.2 kW.

CUBE

Oil-injected rotary screw compressors, with direct transmission and power range from 4 to 7.5 kW.

MICRO - PLUS

Oil-injected rotary screw compressors with belt transmission, at fixed or variable speed and power range from 2.2 to 75 kW.

OS Scroll

Single and multi-scroll fixed speed oil-free compressors with power range from 2.2 to 30 kW.

AIR TREATMENT

Air driers, filters, accessories and a wide range of products for compressed air treatment.



The "Trust" warranty can be easily extended online through EasyConnect, the new Fini service portal specially created to simplify customers' lives by providing them with quick, clear responses about product availability, order management and goods shipping times.

Protect your investment, extend the warranty up to **5** years!

When installing your new Fini screw compressor, join the "Trust" Warranty 3- to 5-year extension program to benefit from countless advantages by maximising the effectiveness, safety and duration over time of your investment. Thanks to scheduled maintenance programs exclusively performed by FINI Authorised Assistance Centres, you can rely on timely, highly professional service, as well as on the use of only original spare parts guaranteed by the FSN brand.



FNA S.p.A. Via Einaudi, 6 - 10070 Robassomero (TO) - Italy
T: +39 011 92 33 000 - F: +39 011 92 41 138
info@fnacompressors.com - www.fnacompressors.com



a brand of



follow us on:



www.finicompressors.it